

B 232 Assembly instructions

VOSS quick connect system 232

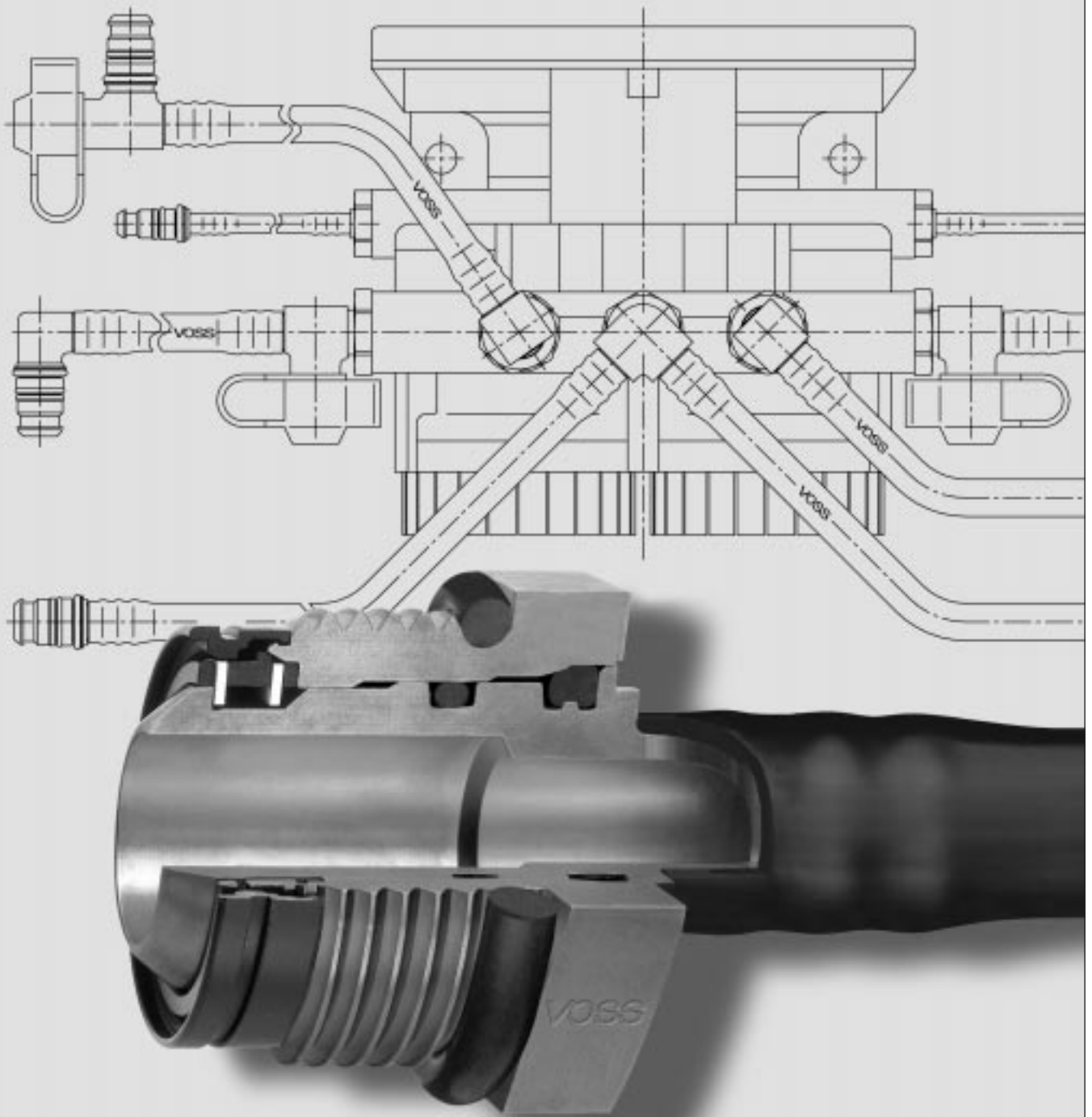

VOSS quick connect system 232 for pneumatic systems in commercial vehicles

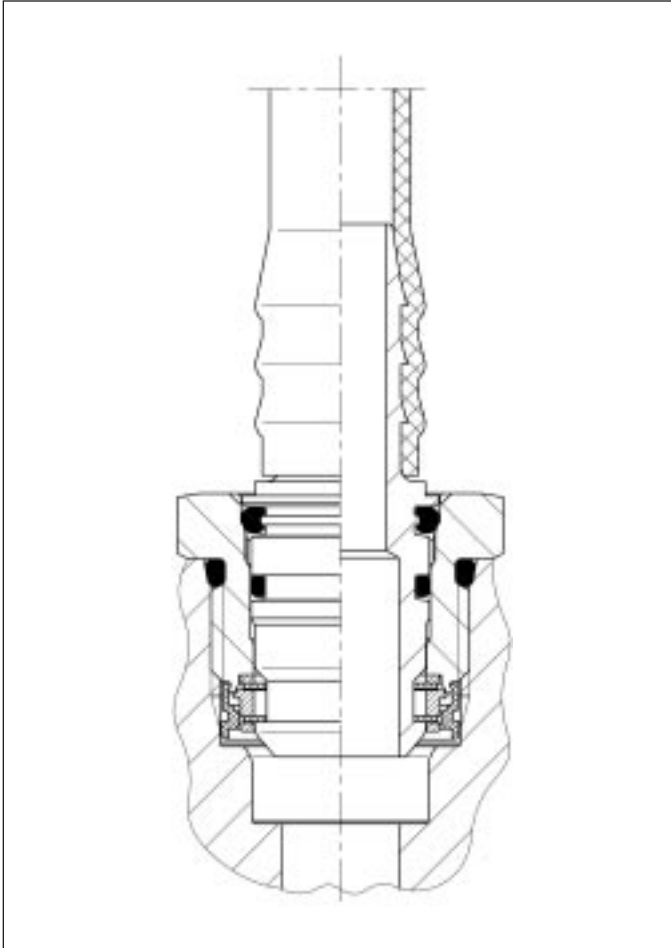

These assembly instructions are intended for qualified fitters of pneumatic systems in commercial vehicles.

1. Introduction

Nylon tube lines are in general use today in pneumatic braking systems in commercial vehicles. Nylon tubes are insensitive to corrosion, vibration and torsional stress in vehicle bodywork.

The following factors are essential for their functional reliability:

- Correct material and proper handling
- Appropriate connection fittings
- Correct assembly

As a connecting element between nylon tubing and components, the VOSS quick connect system 232 permits rapid and safe connection.

2. Nylon tubing

The properties of nylon tubing and details of its use in commercial vehicles are defined in the following standards:

DIN 73 378
Polyamide tubing for motor vehicles

DIN 74 324, Part 1
Air braking systems - thermoplastic tubing; part 1: requirements and tests

DIN 74 324, Part 2
Air braking systems - thermoplastic tubing; part 2: guide for assembling

Only nylon tubing which conforms to DIN 74324 part 1 and made of polyamide 11 or polyamide 12 may be used.

VOSS quick connect system 232

3. VOSS quick connect system 232

The VOSS quick connect system 232 permits rapid assembling of nylon tubes to components. The only tool required for disconnection is a wrench (for width across flats, see section 4.3).

The connecting fittings are made from brass, die-cast aluminium, die-cast zinc, aluminium or nylon, depending on the general conditions. In their standard design, the plugs are available in brass. Individual plug variants are also available in nylon (PA 11 – GF30). Nylon and brass plugs are mutually replaceable. The dimensions of nylon plugs differ from those of brass plugs (see table in section 4.2.2 page 6).

The drawings and tables of dimensions contained in these assembly instructions refer to the brass plug model.

When inserting the nylon plug into the tube, due consideration has to be given to the greater length of the fir-tree compared to the brass model (see section 4.2.2).

3.1 Range of application

The individual components in the VOSS quick connect system 232 are designed for a working temperature range of between -40°C and +100°C.

Their rated operating pressure is 15,5 bar and is limited by the compressive strength of the nylon tubing used.

Possible applications for other service conditions are available on request.

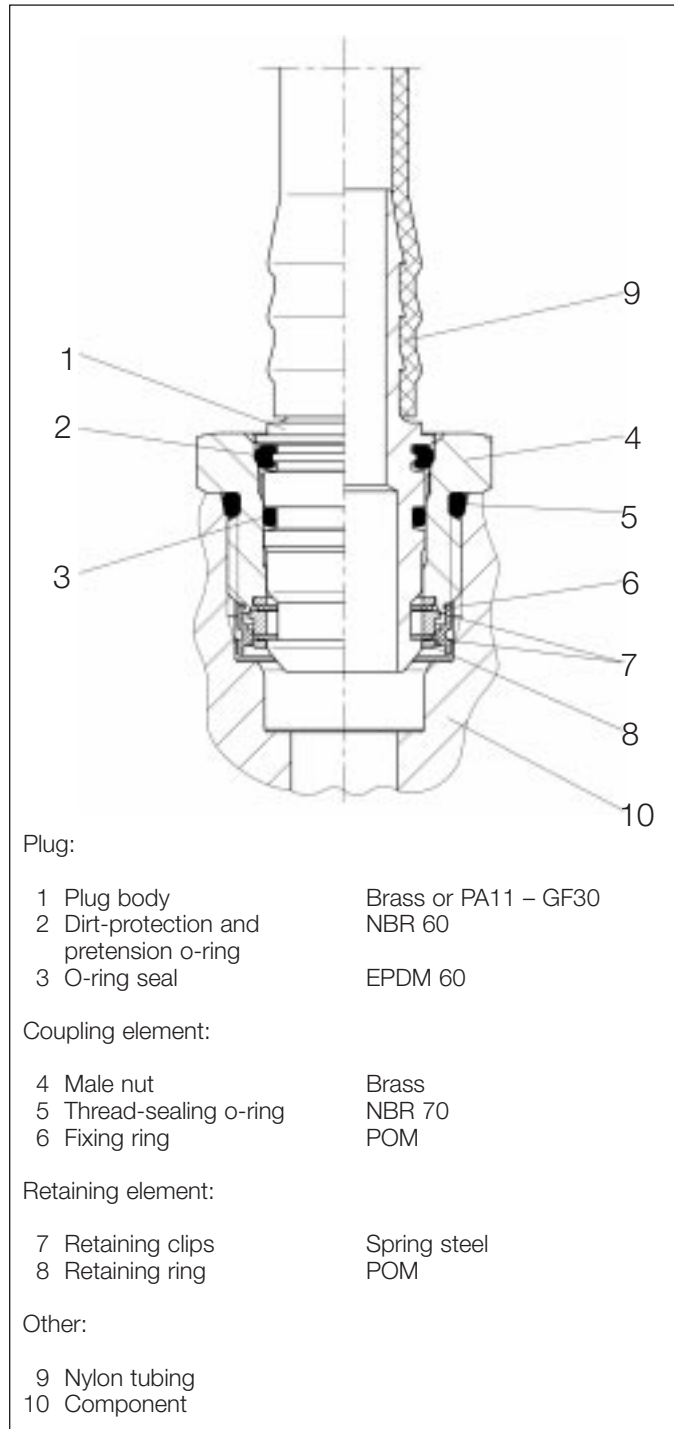

Individual components of VOSS quick connect system 232

CAUTION!

Due to the different material properties, particular attention should be paid to the instructions for nylon plugs contained in section 6.

3.2 Individual components/materials

The VOSS quick connection system 232 consists of two main assemblies: the plug with its fir-tree and the coupling element.

Plug

The plug has a broad retaining groove, the reverse flank of which is inclined at 45°. This protects the clips which snap into place during assembly from being subject to excess tension.

There are two additional grooves, both for o-rings. The first o-ring (3) functions as a seal against the medium being transported.

The second, exterior o-ring prevents contamination from penetrating the connection. In addition, the specially designed groove geometry exerts an axial pre-tensioning force on the plug, when the clips have snapped into place.

The reduced plug diameter above the exterior o-ring (2) acts as a stabilising factor on the coupling element and at the same time provides optical assistance during assembly.

Coupling element

The coupling element is screwed tightly into the component. An o-ring acts as a seal in the threaded port (5).

The two-step retaining element is clipped to the male nut (4) by means of a fixing ring (6). The retaining element contains the retaining ring (8) and two metal clips (7) which lock into place in the retaining groove once the plug has been pressed into the end position.

3.3 Functional description

The coupling element forms the connection to the component. Connection is made by screwing the coupling element into an appropriate port.

Suitable ports are the industrially standard moulded port for the VOSS quick connect system 230 and special port shapes agreed with VOSS for the application in question.

On request, we will be pleased to supply design specifications for the appropriate port.

The connection between a nylon tube and a component is made by sliding the plug into the coupling element.

When this is done the plug is kept in place by a two-stage retaining element which, once it has reached its second snap-in location, is automatically shifted from the push-in to the locking position by means of axial compression and the pressure of the compressed air.

Should the second snap-in stage not be reached due to insufficient insertion force or other unfavourable circumstances, the plug is safe from disconnection as soon as the retaining element has snapped into the first stage.

It is possible to push the retaining element into this first snap-in stage by applying very little force. In this retention position, the connection has an intended leakage path.

Incomplete connections may be noticed by an acoustic warning signal and a drop in pressure.

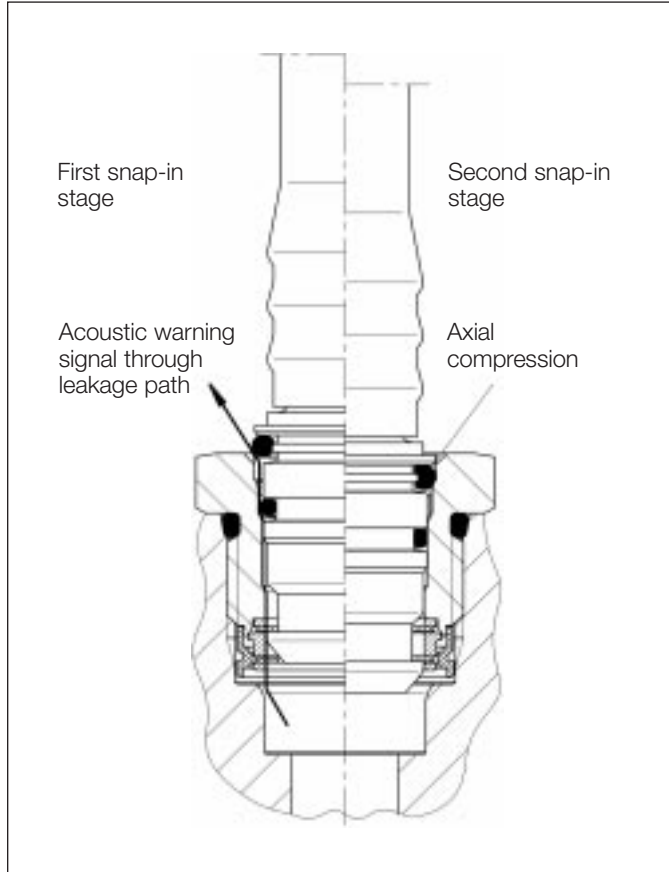

VOSS quick connect system 232, functional diagram

Screw-in thread	Nominal size NS	Fir-tree for tubes O.D. x wall thickness
M 16 x 1.5	8	6 x 1 8 x 1/9 x 1.5 10 x 1,25 10 x 1/11 x 1.5 12 x 1.5
M 22 x 1.5	12	6 x 1 8 x 1/9 x 1.5 10 x 1.25 10 x 1/11 x 1.5 12 x 1.5/14 x 2.5 12,5 x 1.25/14 x 2 16 x 2

Possible combinations of thread size, nominal size and tube dimensions

CAUTION!

The chart obtains only for metallic housings. For nylon housings the VOSS V-thread has to be used.

Retention of the plug in the first snap-in stage thus solves the safety problem of faulty insertion, leading to sudden failure of the connection and subsequent breakdown of the entire system. Compensation for the minor leakage is topped up by the compressor.

3.4 Product range

The VOSS quick connect system is available in nominal sizes 8 and 12.

Please refer to the table below for possible combinations of plug size and nylon tubing dimensions.

The entire range of parts and accessories for the VOSS quick connect system 232 is contained in catalogue 232.

4 Assembly instructions

4.1 Cutting nylon tubing to length

The nylon tube must be cut off square. A saw may not be used for this purpose as the possible formation of burrs will jeopardise the sealing capability of the connection. For cutting nylon tubing to the correct length, we recommend the use of the VOSS cutting pliers shown on the right, which ensure that the tubing is cut squarely and cleanly. Subsequent treatment of the cut surface such as deburring is no longer necessary then.

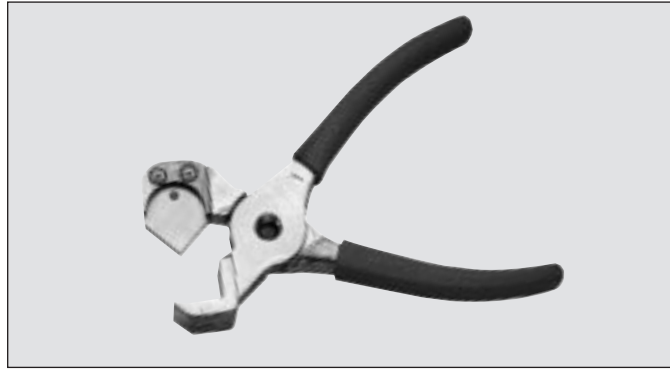

Nylon tube pliers

4.2 Insertion of the fir-tree in nylon tubing

The following has to be observed when pressing the fir-tree into the nylon tube:

- Insertion procedure must be carried out at room temperature
- Nylon tube may not be heated
- Fir-tree must be undamaged as the connection to the nylon tubing will otherwise not be tight
- Fir-tree must be clean and free of any grease

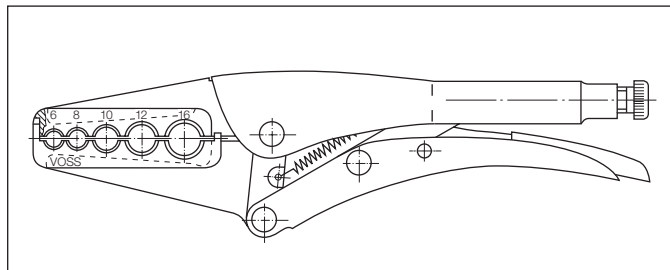

Nylon tube collet

4.2.1 Insertion of the fir-tree with the nylon tube collet

Insert the nylon tube into the opened pliers in such a way that the end of the tube extends approx. 2 mm for brass plugs and approx. 6 mm for nylon plugs from the side of the pliers without serration. Fix the nylon tube into place with the grip mechanism. The clamping force exerted may be varied by means of the adjusting screw.

Press the fir-tree as far as possible into the end of the tube manually. Then drive the plug into the polyamide tube with the aid of a plastic hammer until the fir-tree is fully covered by the tube. The plug has to be protected by a plastic cap.

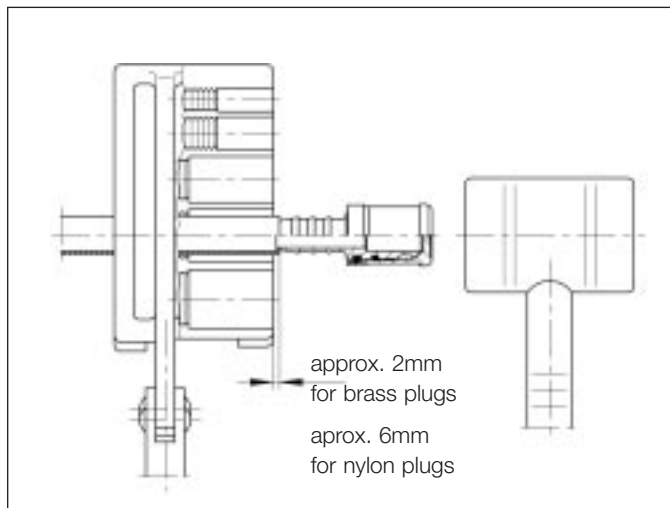

Insertion of the fir-tree with nylon tube collet

CAUTION!

The connection between nylon tubing and fir-tree must under no circumstances be secured by hose clips or by clamping sleeves.

4.2.2 Insertion of the fir-tree with manual assembly tool

The tube clamping jaws should be turned in the correct position until they match the outer diameter of the tube to be mounted. A tool insert corresponding to the plug to be fitted (NS 8 or NS 12, straight or shaped plug) should then be placed into the fixture.

The diameter d_3 of the fir-tree should match the internal diameter of the nylon tube (see table). This ensures that the required pretension pressure of tube onto the fir-tree is reached.

Next place the nylon tube in the jaws, allowing it to protrude by the length L (see fig.), and firmly secure the nylon tube by tightening the vicegrip. The clamping force exerted may be varied by means of the adjusting screw.

The plug to be fitted should then be placed in the tool insert with a protective cap and the transport bar pressed manually towards the nylon tubing until the fir-tree is pre-centred in the tube end.

Now the nylon tube can be pressed onto the plug as far as the end of the fir-tree by using the insert lever.



Manual assembly tool

NS	d_1 (mm)	Tube O.D. x wall thickness	d_3 (mm)	d_4 (mm)	a (mm) (brass/nylon)
NS 8	9.7	6 x 1	4.6	4.0	16
		8 x 1/9 x 1.5	6.9	6.0	16
		10 x 1.25	8.1	7.5	22
		10 x 1/11 x 1.5	9.0	8.0	22
NS 12	15.2	6 x 1	4.6	4.0	16
		8 x 1/9 x 1.5	6.9	6.0	16
		10 x 1.25	8.1	7.5	22
		10 x 1/11 x 1.5	9.0	8.0	22
		12 x 1.5/14 x 2.5	10.3	9.0	22/26
		12,5 x 1.25/14 x 2	11.2	10.0	22
		16 x 2	13.6	12.0	25

Possible combinations of tube dimensions and fir-tree dimensions

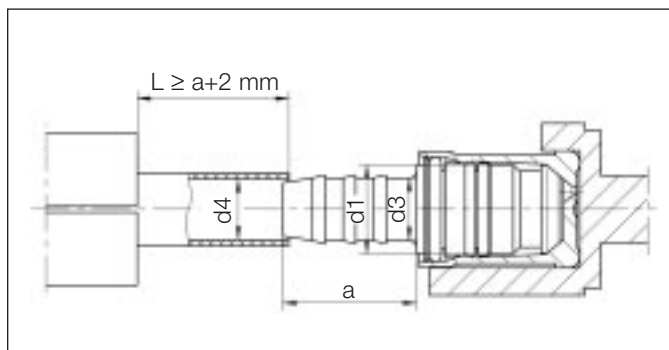

Outline of tube and plug dimensions

4.2.3 Protective cap

All plugs are supplied with a protective cap to protect the neck of the plug and the o-rings from damage and dirt. This protective cap should not be removed until immediately before final assembly.

4.3 Assembly of the coupling element

In order to achieve safe functioning, the connecting port should be cleaned before fitting the coupling element.

In particular, any residue of paint still attached to the region of the sealing lip should be removed. Care is also be taken to ensure that the thread of the component is at right angles to the contact surface of the coupling element.

The coupling element consists of a male nut (1) with greased thread-sealing o-ring (2) and retaining element (4) clipped into place with a fixing ring (3). It is available from the factory with or without paint protection stickers. If there is a paint protection sticker on the front of the coupling unit, it should not be removed. The coupling unit is screwed hand-tight into the connecting port. When the coupling element is inserted into the thread, the fixing ring acts to pre-align the coupling element, thus facilitating the assembly.

Now the coupling element should be tightened with a torque wrench. For this purpose, the flap of the paint protection sticker should be folded upward. The recommended tightening torques are listed in table on the right. The values quoted are valid both for metal (die-cast aluminium, die-cast zinc) and for nylon casings (PA-GF30) with VOSS V-thread.

Automatic VOSS assembly tools are available on request for high volume assembly.

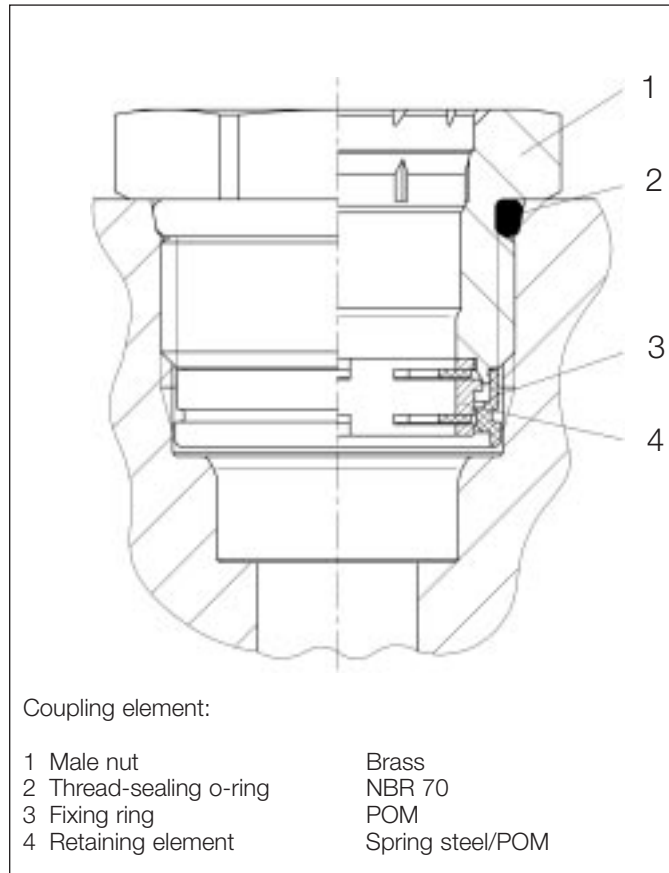

Individual components of the coupling element

Thread sizes	Nominal size	Across flats	Tightening torque Nm
	NS		
M 16 x 1.5	8	19	10 - 17
M 22 x 1.5	12	24	10 - 17

Tightening torque of VOSS quick connect system 232

4.4 Connecting line to component

Now the protective cap can be removed from the plug (see section 4.2.3) and the paint protection sticker can be removed from the coupling element (see section 4.3).

Slide plug with nylon tube fitted to fir-tree into the port of the coupling element. The plug must overcome the axial force exerted by the dirt-pro-

tection and pretension o-ring while being pressed into the coupling element, until both clips snap into place in the groove of the plug.

The first clip snaps into place when only very little force is applied. In this initial retention position, the connection is already secured against unintentional loosening, but it is not yet leak-tight. The connection is not fully sealed until the second clip snaps into

place. To conclude the insertion process, check the clips have snapped into place correctly by pulling in the opposite direction from that used for insertion. Always ensure that the connector does not sit at a false angle in the port. It should not be possible to pull back the connector when checking whether it has been correctly fitted.

The connection has been correctly made, if after pulling back the plug the shoulder (dirt-protection and pretension) o-ring is located below the top face end of the coupling element and thus the o-ring is not visible.

Incorrect connections, i.e. plug connectors in the first stop position, can be reconnected to the second stop position, also if the system is pressurized (< 7 bar). This will not result in damage. Whether reconnection is possible also depends on the possible insertion force at the installation location.

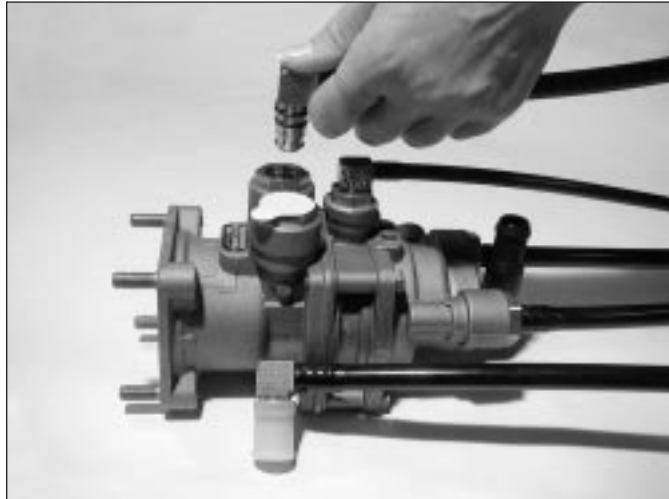

Final assembly:
Inserting plug and subsequently pulling back to check correct fitting

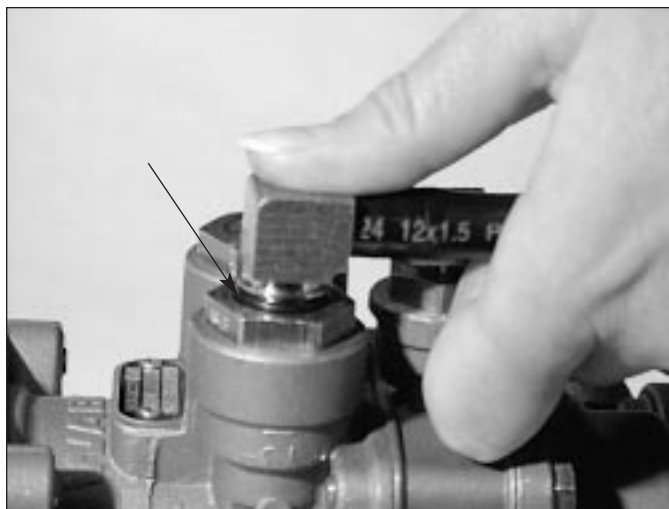

Final assembly:
Incomplete connection at first snap-in stage; the dirt-protection and pretension o-ring is visible after pulling back the plug.

4.5 Disconnecting and reassembling

The pneumatic line connected must be free of any pressure before it is detached. If the plug is detached while the line is pressurised, it can cause personal injury and damage to connecting components or to the pneumatic unit. These damaged components must then be replaced. All individual components must be cleaned before reassembly.

In order to replace components, loosen the male nut and remove the connection. The nylon tube with plug and coupling element with o-ring need not be separated.

Check the port on the new unit is clean. Then re-grease the thread-sealing o-ring, screw in coupling element with plug, fitted with nylon tube and tighten male nut. (For tightening torque, see section 4.3).

CAUTION!

Connections which have not snapped into place can impair braking performance and may even lead to failure of the entire pneumatic system.

4.6 Assembly tools

The following tools are available from VOSS for assembling quick connect system 232:

Series assembly

- VOSS type 56 assembly machine for inserting fir-trees into nylon tubing

Small series or individual assembly

- Manual assembly tool
- Nylon tube collet
- Nylon tube pliers

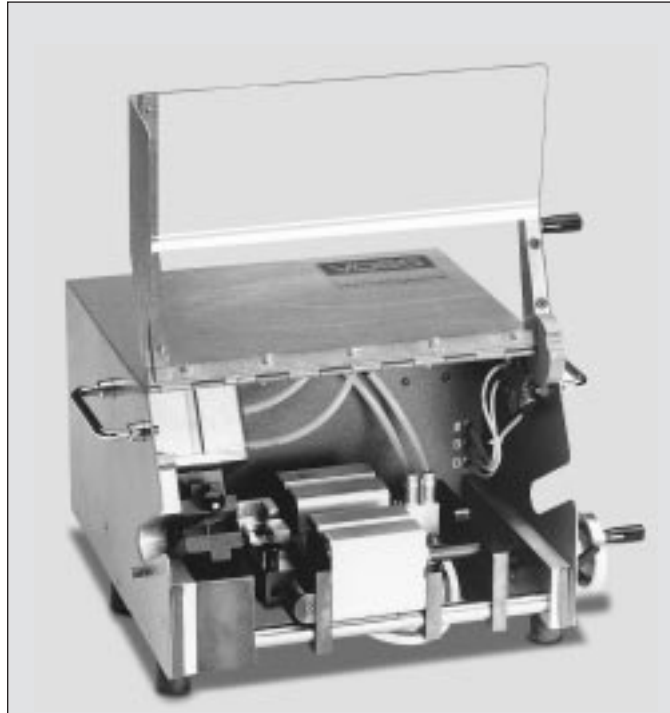

VOSS type 56 assembly machine

Service case 1:

- 1 nylon tube collet for external tube diam. 6, 8, 10, 12, 16
- 1 plastic hammer
- 1 nylon tube pliers
- 1 wrench 24/19 width across flats

Service case 2:

- 1 manual assembly tool with tube clamping jaws for external tube diam. 6, 8, 10, and 12 and for external diam. 11, 12, 14 and 16
- 1 tool insert for straight connectors NS 8
- 1 tool insert for straight connectors NS 12
- 1 tool insert for right-angle connectors NS 8 with tubing 6 x 1, 8 x 1 and 9 x 1.5
- 1 tool insert for right-angle connectors NS 12 with tubing 6 x 1, 8 x 1 and 9 x 1.5
- 1 tool insert for right-angle connectors NS 12 with tubing 10 x 1.25 and 12 x 1.5
- 1 tool insert for right-angle connectors NS 12 with tubing 16 x 2
- 1 nylon tube pliers
- 1 wrench 24/19 width across flats

Operating instructions and product descriptions are available for the assembly tools mentioned above; we will be pleased to send you these on request.

5. Repairs

The components of VOSS quick connect system 232 do not wear or tear as a result of operation.

Should any of the components be damaged as a result of inappropriate handling, these may be replaced as required.

5.1 Replacing the thread-sealing o-ring

The old o-ring can be removed when the system is disconnected from the component (see section 4.5). Clean the groove in the coupling element carefully and check that it is not damaged. The coupling element must be replaced if there are any signs of damage (see section 5.2).

Then replace the old o-ring with a new one which has been greased. All damage, excess stretching or twisting of the o-ring is to be avoided when fitting.

5.2 Disconnecting coupling element

Break the connection (see section 4.5) and lever off the fixing ring using a suitable tool (see fig. 1). Take care that the plug is not damaged in this process.

Then pull the clips sideways out of the retaining ring. This can be done by inserting a pointed tool through the slot in the cage behind the clips (see fig. 2).

Once the two clips and the retaining ring have been removed, the plug may be pulled out of the male nut.

A suitable disassembly tool is available on request.

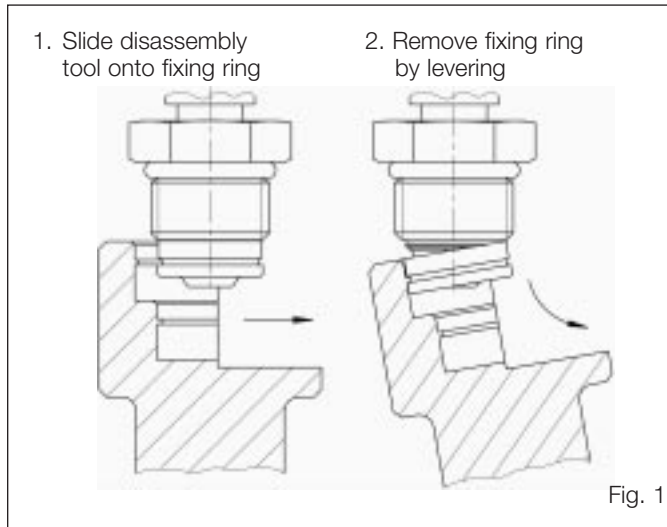

Fig. 1

Levering off fixing ring

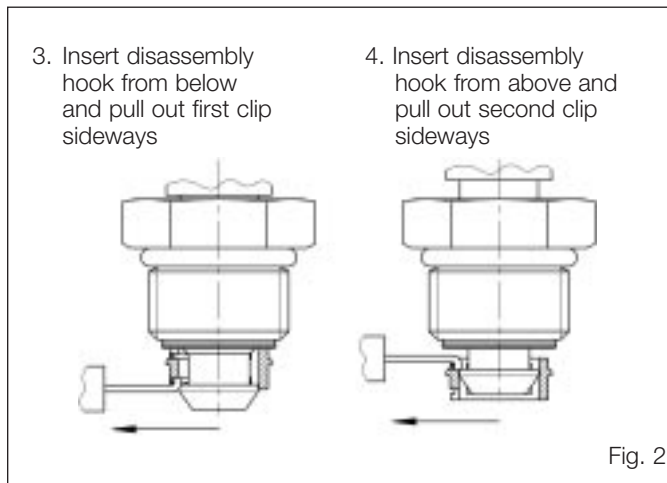

Fig. 2

Removing clips

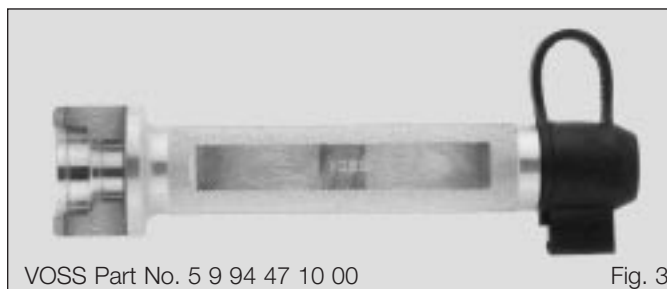

Fig. 3

Disassembly tool for the coupling element

CAUTION!

Always use a new coupling element for reassembling whenever male nut and plug have been disconnected.

To reassemble, always use a new coupling element whenever the plug has been removed from the male nut. In addition, the o-rings for the plug must be checked, replaced if necessary and re-greased.

5.3 Replacing plug o-rings

The damaged o-ring can be removed after disconnection (see section 5.2). Clean the groove carefully, and then replace the old o-ring with a new one which has been greased. All damage, excess stretching or twisting of the o-ring is to be avoided when refitting. This applies both to the sealing o-ring and to the dirt-protection and pretension o-ring.

5.4 Lubrication of the o-rings

In order to ensure the functional reliability of the o-rings, use only grease that has been tested and approved by VOSS.

Approved lubricating greases are:

- Bechen – Berulub Hydrohaf 2
- Bechen – Berulub Hydrohaf GR
- Klüber – SYNTHESO GLEP 1

6. VOSS quick connect system 232 with nylon plugs

6.1 Reduced impact toughness

The VOSS quick connect system 232 with nylon plug is a variant of the same system with a brass plug; it can be installed in the same valves and other components in pneumatic braking systems. See the figure on the right for a comparison of the nylon and brass plug.

In contrast to the plugs made of brass, nylon plugs have considerably lower impact strength over the entire temperature range from -40°C to +100°C. The result is a reduction in safety reserves with respect to impact load (during initial and repeated assembly, when handled inappropriately during service operations, when stepped on, when subjected to flying stones while driving, etc.)

6.2 Long-term behaviour

Nylon has a different longterm behaviour with respect to strength and shape stability. It should therefore be protected against extremes of temperature (e.g. radiating engine heat).

7. Further information

Plugs should not be subjected to damage during assembly or servicing or while the vehicle is being driven as the functions of the pneumatic braking system might otherwise be impaired. After assembly or service operations, it is imperative to check the operational reliability of the system (pressure test). The connections should be shielded against damage by appropriate layout and positioning (e.g. protected by cover plates.)

Due attention is to be paid to the limits of application of the



Comparison between brass and nylon plugs of VOSS quick connect System 232

materials under extreme working conditions (see section 3.1).

Air lines subjected to torsional stress for long periods ($\geq 1/2$ h) at temperatures of $\geq 100^\circ\text{C}$ may become subject to leakage in the region of the fire-tree.

Appropriate safeguards are to be taken because this will affect the function of the pneumatic braking system.

8. VOSS customer service

The VOSS customer service is at your disposal for all questions concerning quick connect systems, nylon tubing, routing of air lines, etc.

9. Industrial property rights

We refer our customers to our national and foreign patents, registered designs, trademarks and property right applications.

Drawings of the VOSS quick connect system 232 may not be reproduced or made accessible to third parties without our prior consent.

We only deliver according to our General Terms and Conditions of Business, which you can download and save from http://doc.voss.de/aga/VOSS-Automotive-GmbH-AGB_eng.pdf. We contradict expressly to regulations to the contrary.

VOSS

VOSS Automotive GmbH
P.O. Box 15 40
D-51679 Wipperfürth
Leiersmühle 2-6
D-51688 Wipperfürth
Tel.: +49 2267 63-0
Fax: +49 2267 63-5982
automotive@voss.net
www.voss.net